



NAKOMA COMMUNITY ASSOCIATION DESIGN REVIEW COMMITTEE PROJECT APPLICATION

PROJECT LOCATION

LOT #	266	ADDRESS	542 Great Spirit, Clio, Ca 96106
-------	-----	---------	----------------------------------

OWNER

NAME	Robin and Marius Sutara		
MAILING ADDRESS			
CITY / STATE / ZIP			
EMAIL	Robin.sutara@hotmail.com	PHONE	(206) 375-4474

ARCHITECT / DESIGNER

NAME	Williams Construction and Design Group, Inc.		
MAILING ADDRESS	P.O. Box 161		
CITY / STATE / ZIP	Clio, Ca. 96106		
EMAIL	mattbuilder@outlook.com	PHONE	(530) 308-1703

CONTRACTOR/ BUILDER

NAME	Williams Construction and Design Group, Inc.		
MAILING ADDRESS	P.O. Box 161		
CITY / STATE / ZIP	Clio, Ca. 96106		
EMAIL	mattbuilder@outlook.com	PHONE	(530) 308-1703

PROJECT INFORMATION

PROJECT TYPE	Single family dwelling with attached garage		
SQ. FT (CONDITIONED)		SQ. FT (UNCONDITIONED)	

As Applicant, either as Owner or Owner's Agent, I have read and understand the NAKOMA COMMUNITY ASSOCIATION CC&R's and the DESIGN REVIEW GUIDELINES dated January 6th, 2021, concerning design and construction at Gold Mountain.

Matt Williams

SIGNATURE

DATE 12/27/2023

Matt Williams

PRINT NAME

Cover Page

Job information

Owners = Robin and Marius Sutara -----(530) 414-4547
 Engineer =LBK Engineering------(530) 249-3529
 Designer = Williams Construction------(530) 308-1703
 Building Department = Plumas County--- (530) 283-7011
 Adress = 542 Great Spirit Gold Mountain Clio, Ca. 96106
 A.P. Number = 031-250-006

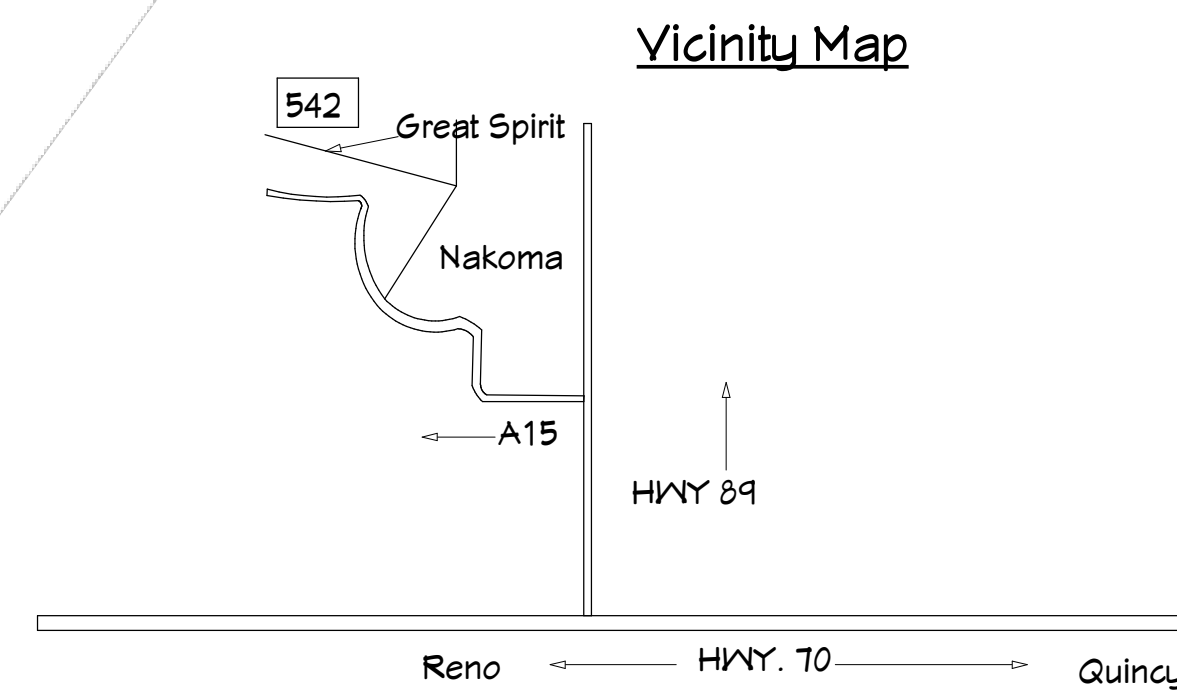
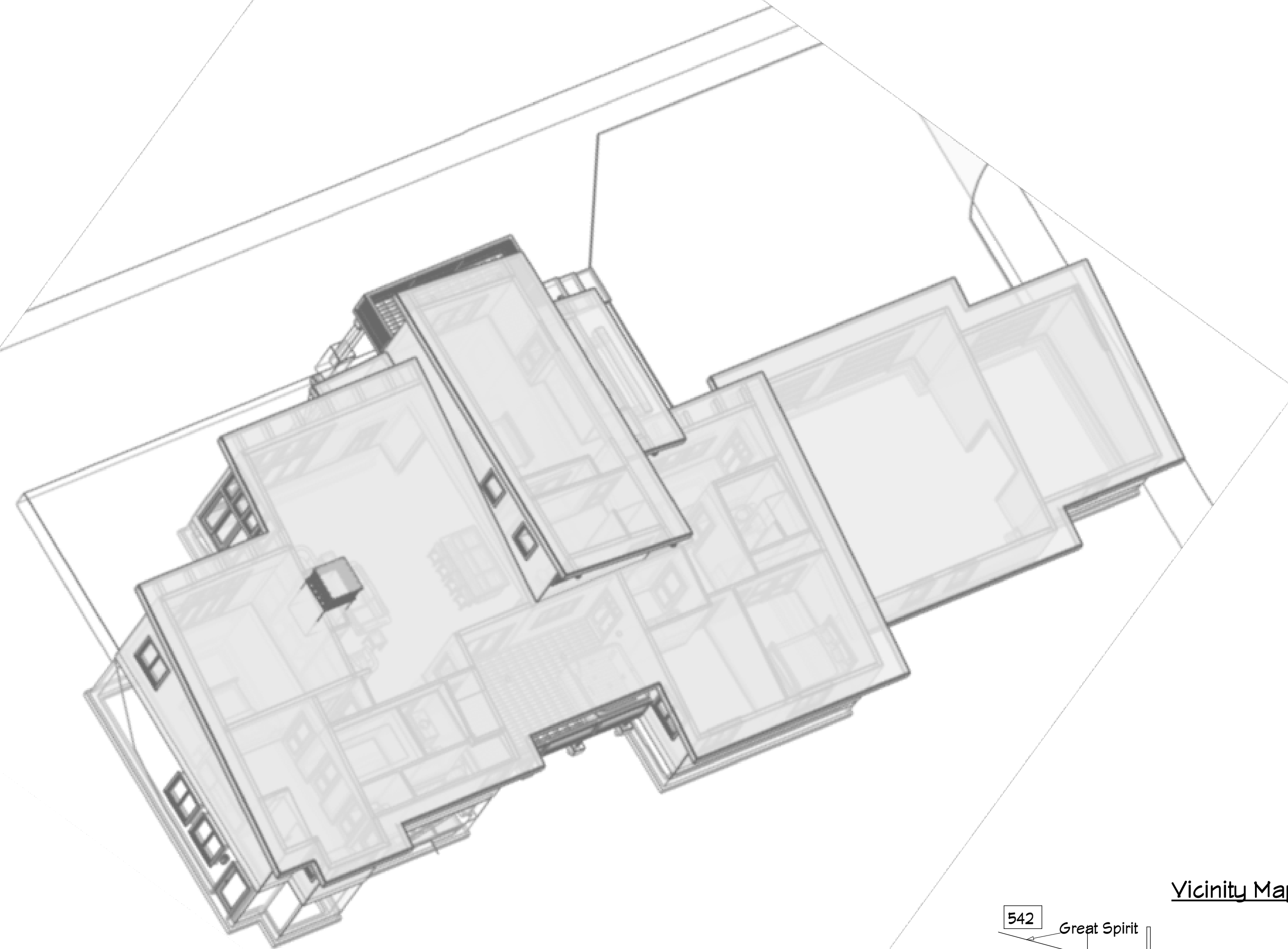

Square footage numbers

Conditioned living space = 3035
 Garage = 1050
 Covered entry = 38
 Covered Wood Deck = 260
 Paver patios = 698
 Unfinished basement = 625

Table of contents

- A0 = Cover page
- A1 = Site Plan 1"= 30'
- A2 = Site plan 1" = 20'
- A3 = Main Level floor plan
- A4, = upper and basement floor plans
- A5 = Elevations
- A6 = Elevations
- A7 = Roof plans
- A8 = Ortographic rendering
- A9 = Orthographic rendering
- A10 = Photos for exterior color reference
- S1 = Section plan
- S1 = Foundation plan
- S2 = Floor framing plan
- S3 = Roof framing plan
- DT1 = Details
- DT2= Details
- E1 = Electrical plan

NUMBER	DATE	REVISOR	DESCRIPTION



Residence for:
Robin and Marius Sutara
 542 Great Spirit
 Gold Mountain

DRAWINGS PROVIDED BY:
 Williams Construction and Design
 P.O. Box 161 Clio, Ca. 96106
 (530) 308-1703

DATE:

12/27/23

SCALE:

SHEET:

A0

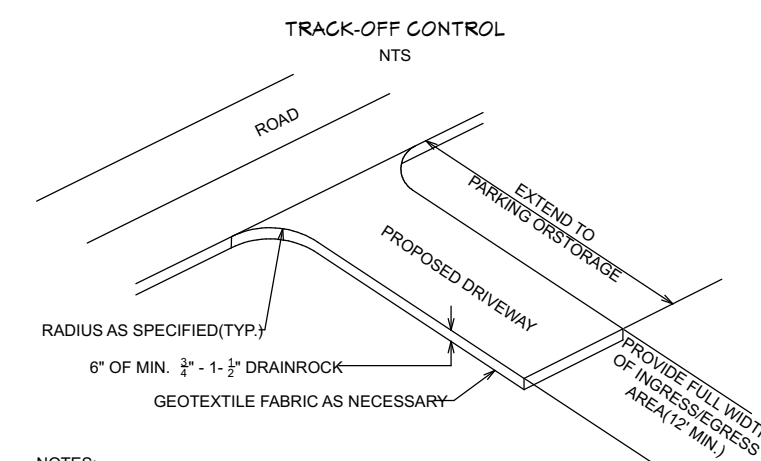
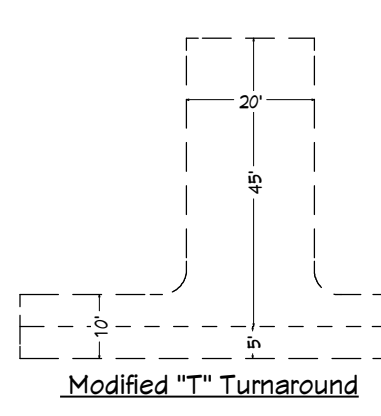
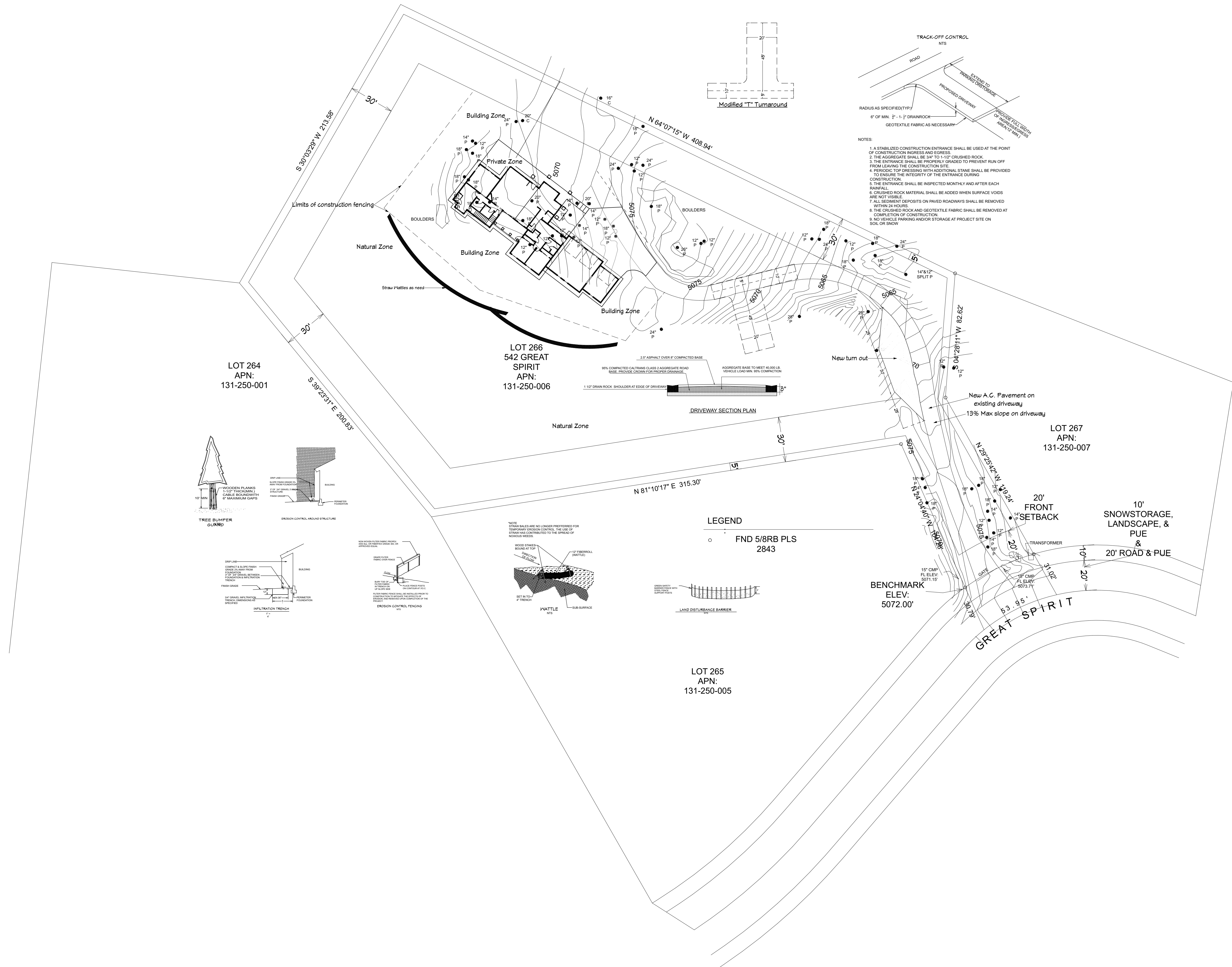

- NOTES:
1. A STABILIZED CONSTRUCTION ENTRANCE SHALL BE USED AT THE POINT OF CONSTRUCTION INGRESS AND EGRESS.
 2. THE AGGREGATE SHALL BE 3/4\"/>

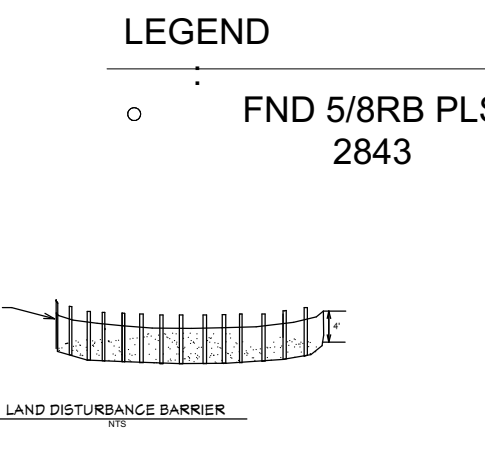
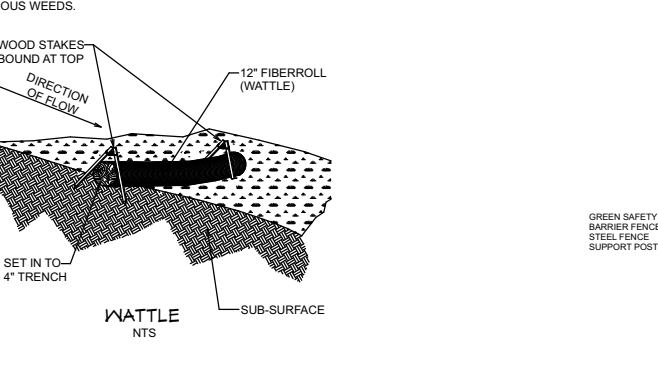
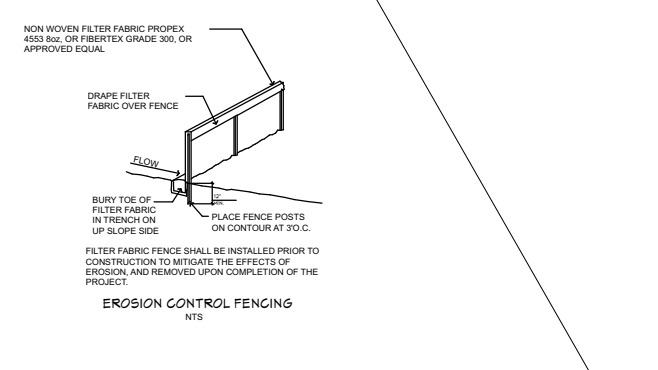
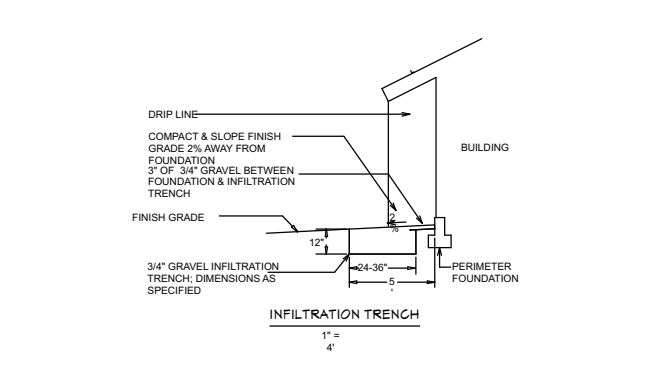
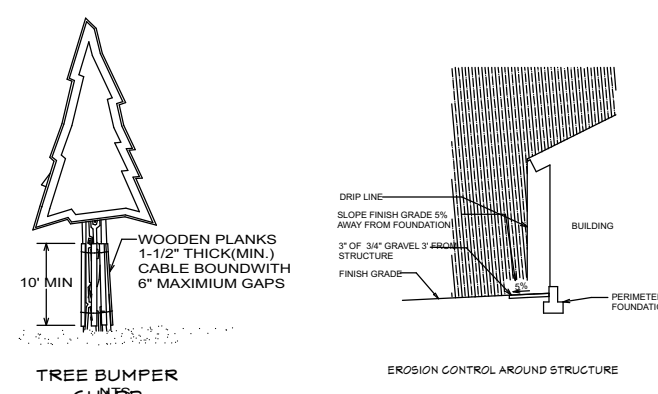

LEGEND
 ○ FND 5/8RB PLS 2843

LOT 264
 APN:
 131-250-001

LOT 266
 542 GREAT
 SPIRIT
 APN:
 131-250-006

LOT 267
 APN:
 131-250-007

LOT 265
 APN:
 131-250-005

REVISION TABLE	
NUMBER	DATE



Residence for:
Robin and Marius Sutara
 542 Great Spirit
 Gold Mountain

DRAWINGS PROVIDED BY:
 Williams Construction and Design
 P.O. Box 161 Clio, Ca. 96106
 (530) 308-1703

DATE:

12/27/23

SCALE:

SHEET:

A1

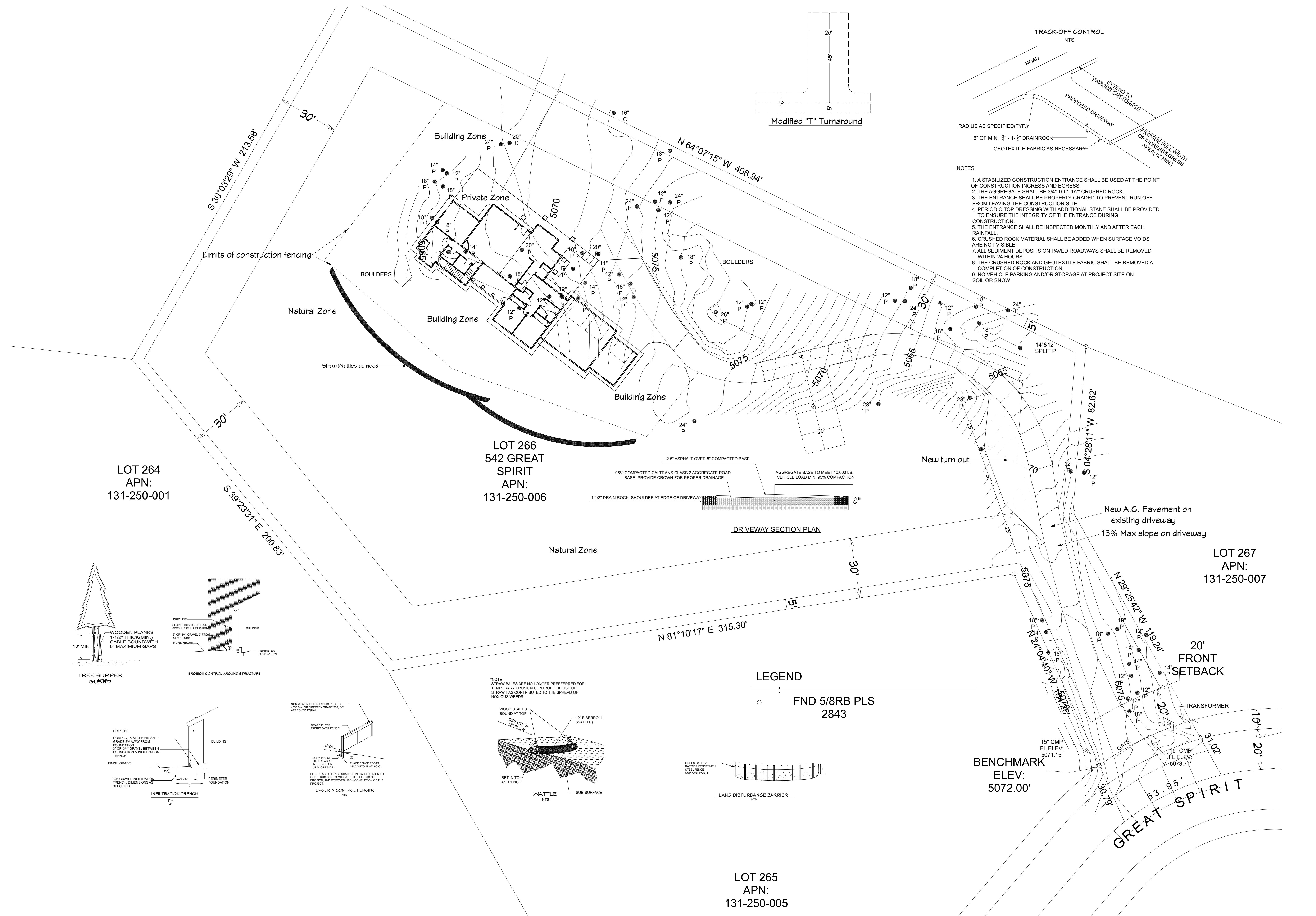

NUMBER	DATE	REVISED BY	DESCRIPTION



Residence for:
 Robin and Marius Sutara
 542 Great Spirit
 Gold Mountain

DRAWINGS PROVIDED BY:
 Williams Construction and Design
 P.O. Box 161 Clio, Ca. 96106
 (530) 308-1703

DATE:
12/27/23

SCALE:

SHEET:
A2

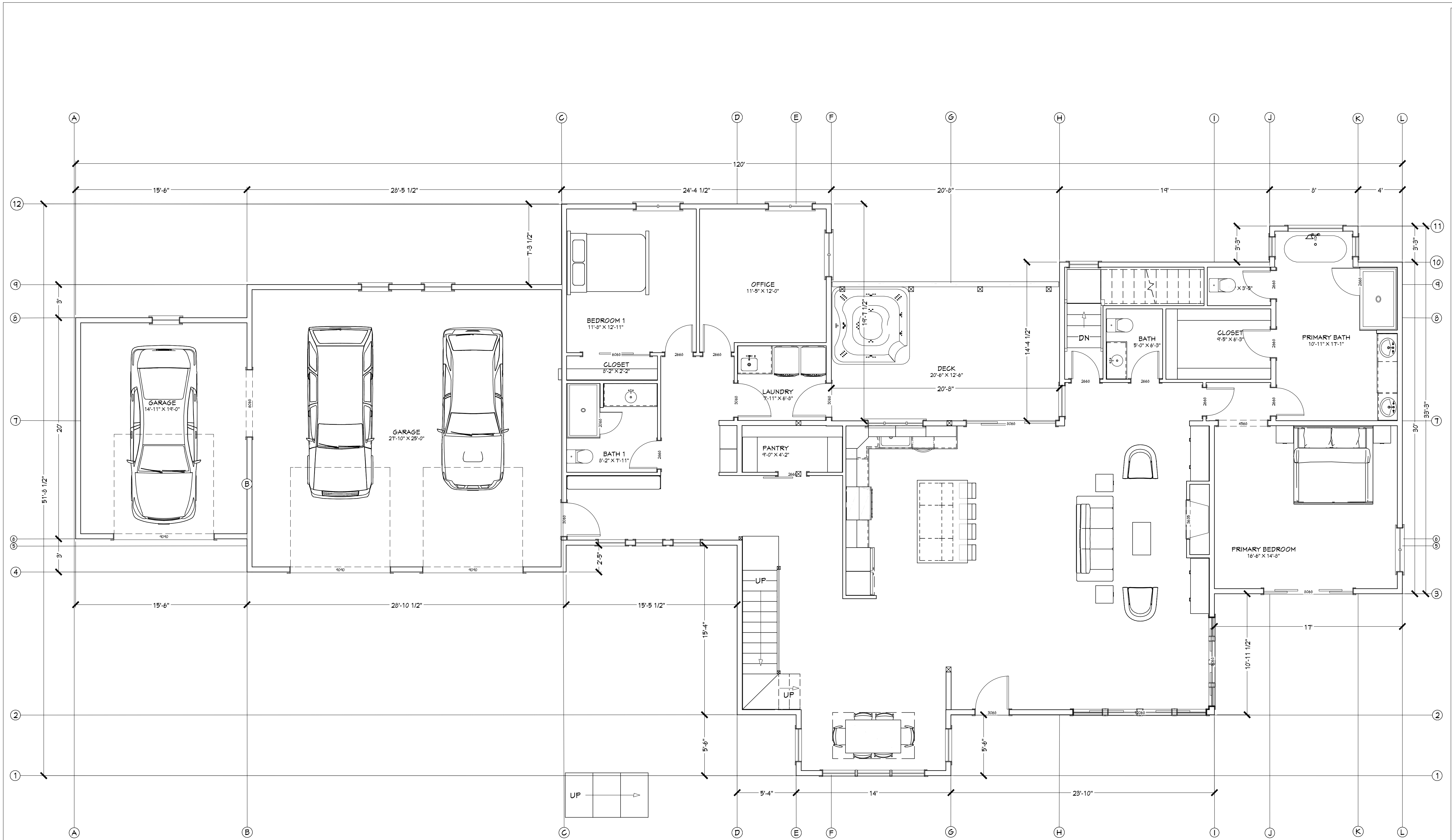

LIVING AREA
2593 SQ FT

NUMBER	DATE	REVISION BY	DESCRIPTION



Residence for:
Robin and Marius Sutara
542 Great Spirit
Gold Mountain

DRAWINGS PROVIDED BY:
Williams Construction and Design
P.O. Box 161 Clio, Ca. 96106
(530) 308-1703

DATE:

12/27/23

SCALE:

SHEET:

A3

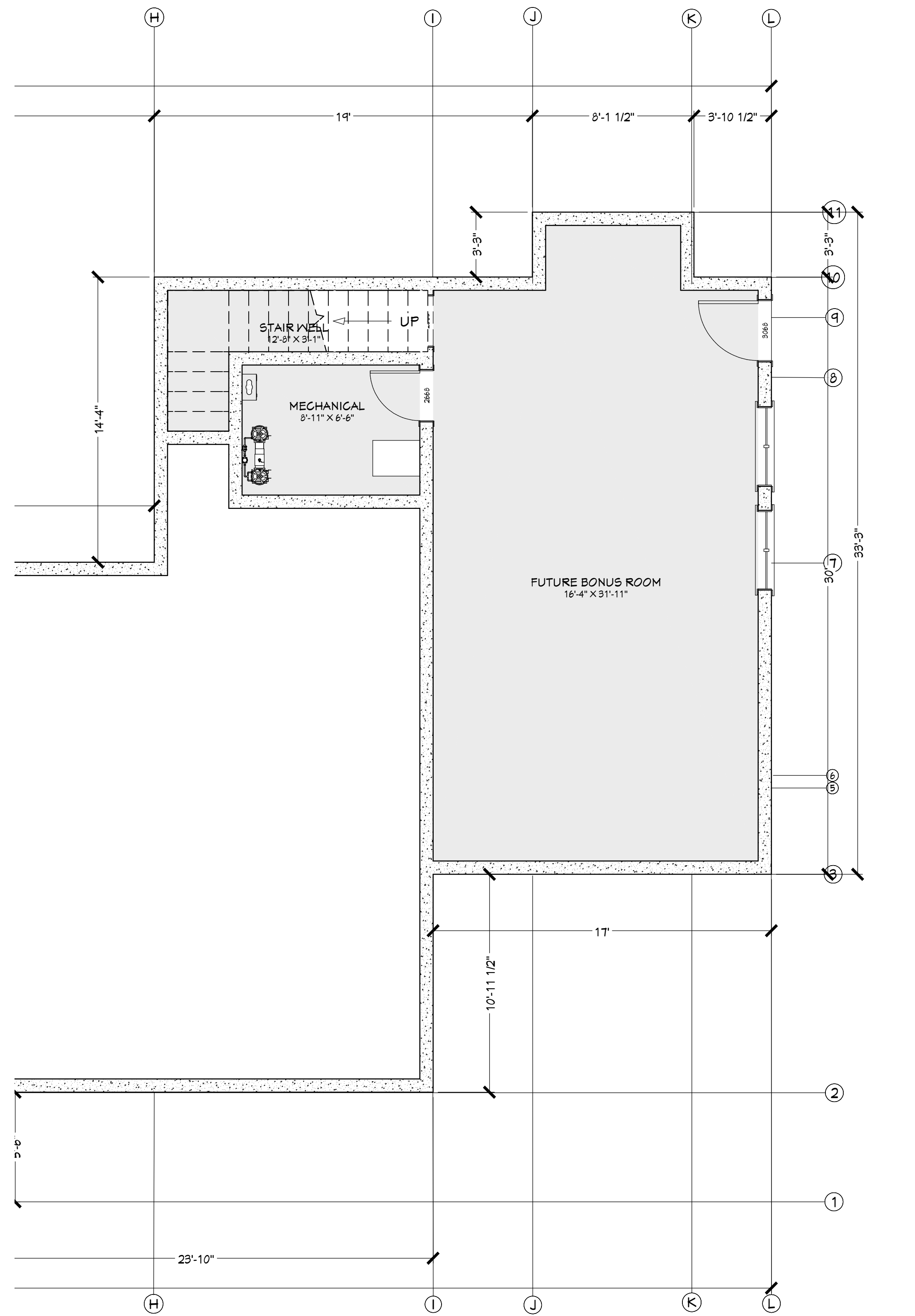

Future bonus room (unfinished)

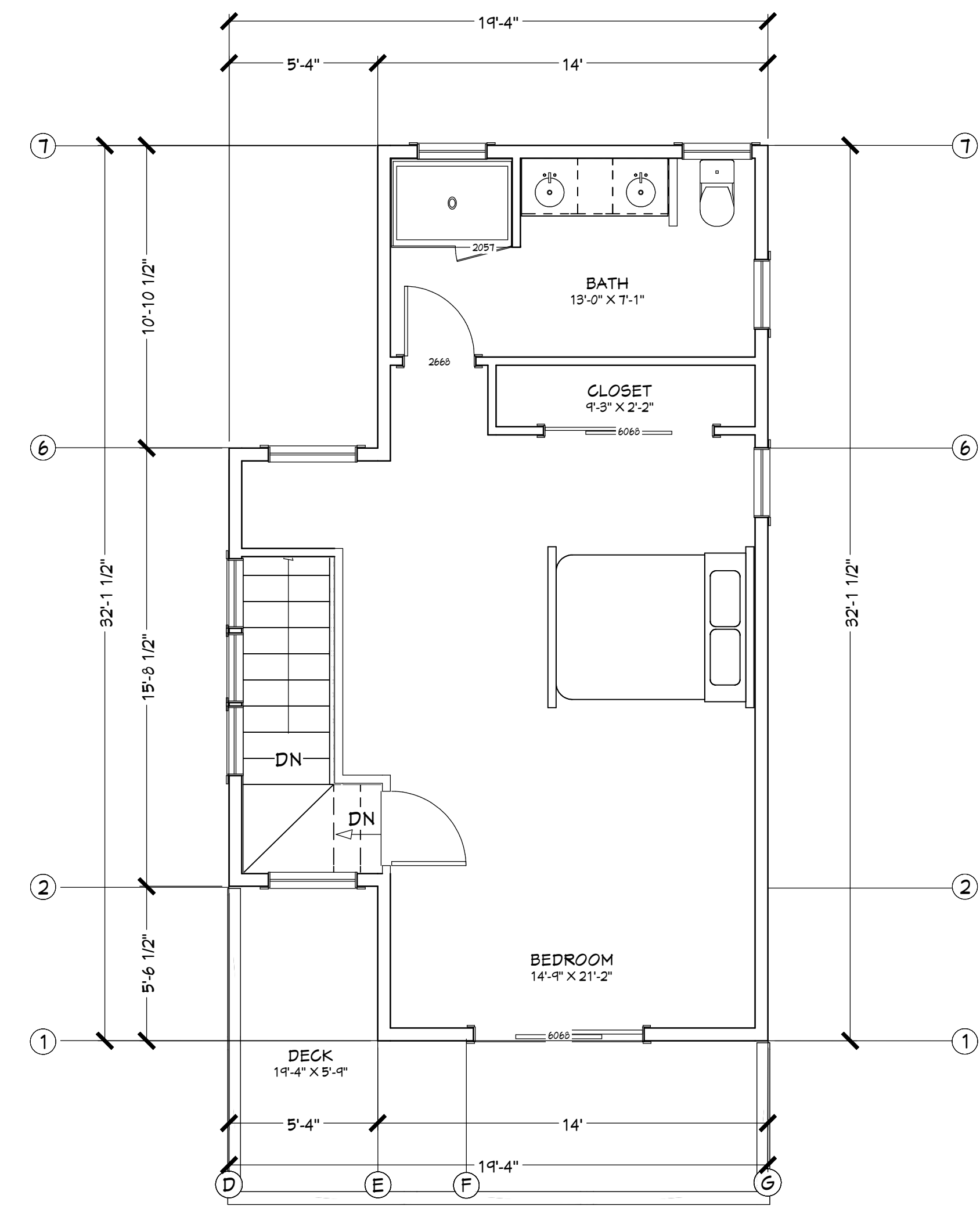

LIVING AREA
482 SQ FT

2nd Floor

NUMBER	DATE	REVISED BY	DESCRIPTION



Residence for:
Robin and Marius Sutara
542 Great Spirit
Gold Mountain

DRAWINGS PROVIDED BY:
Williams Construction and Design
P.O. Box 161 Clio, Ca. 96106
(530) 308-1703

DATE:

12/27/23

SCALE:

SHEET:

A4

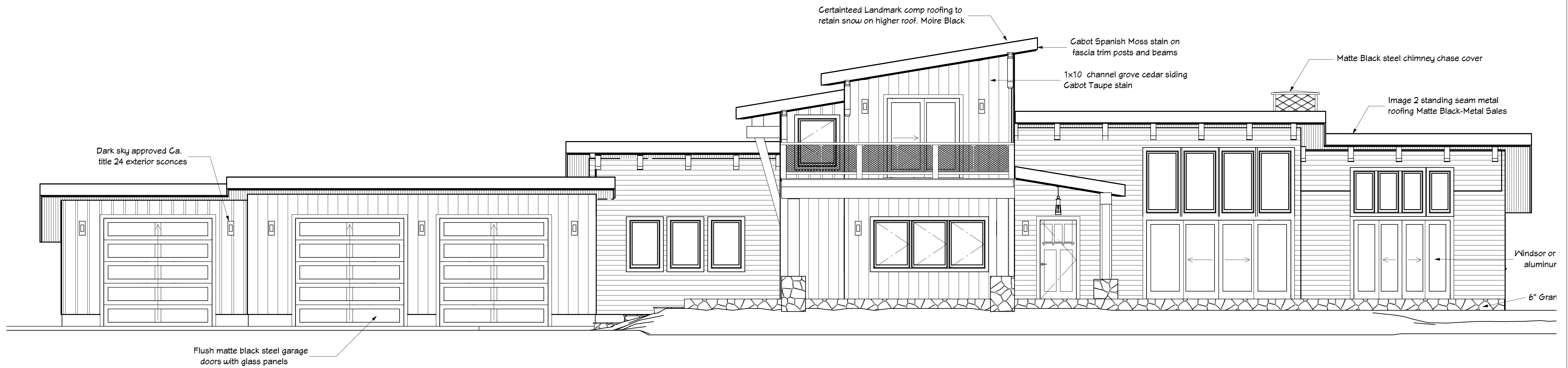

North Elevation

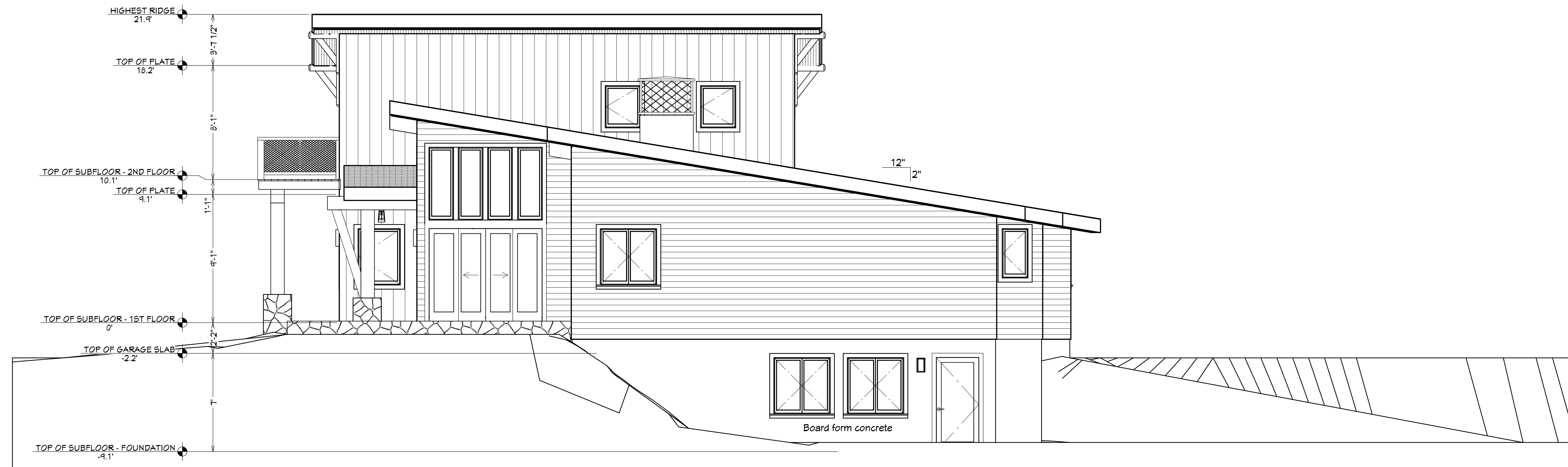

West Elevation

REVISION TABLE	
NUMBER	DATE / REVISION BY / DESCRIPTION



Residence for:
Robin and Marius Sutara
 542 Great Spirit
 Gold Mountain

DRAWINGS PROVIDED BY:
 Williams Construction and Design
 P.O. Box 161 Clio, Ca. 96106
 (530) 308-1703

DATE:

12/27/23

SCALE:

SHEET:

A5

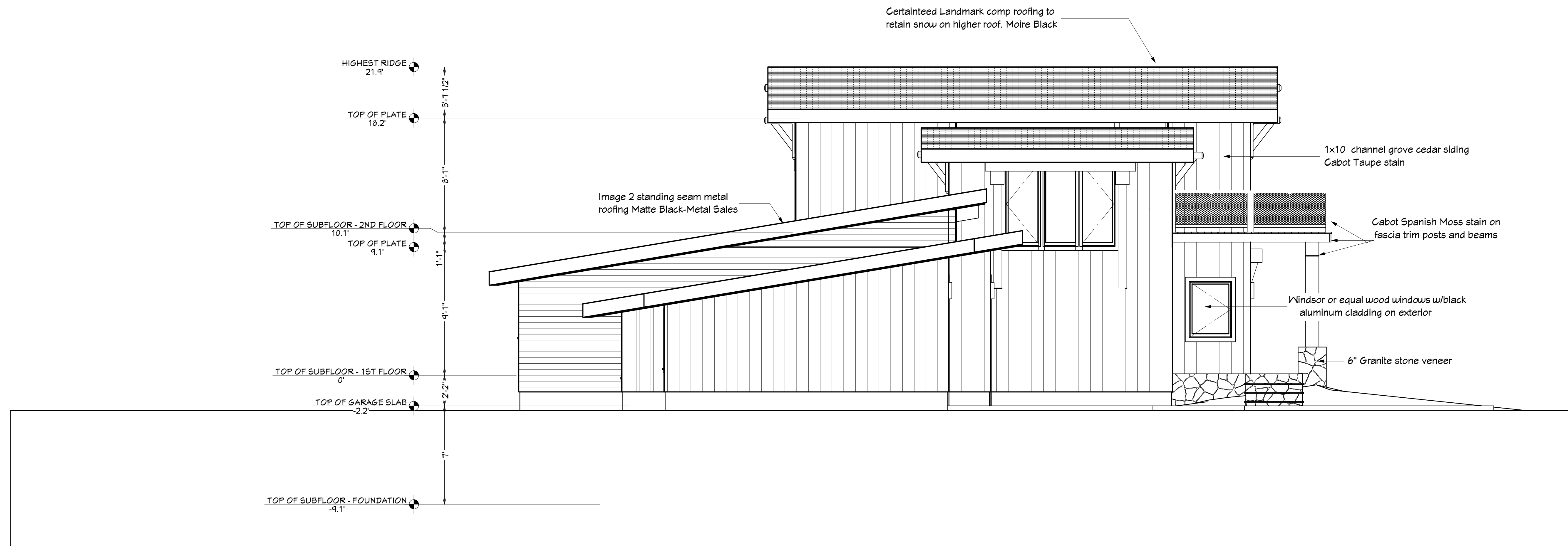

East Elevation



South Elevation

NUMBER	DATE	REVISION BY	DESCRIPTION



Residence for:
Robin and Marius Sutara
 542 Great Spirit
 Gold Mountain

DRAWINGS PROVIDED BY:
 Williams Construction and Design
 P.O. Box 161 Clio, Ca. 96106
 (530) 308-1703

DATE:

12/27/23

SCALE:

SHEET:

A6

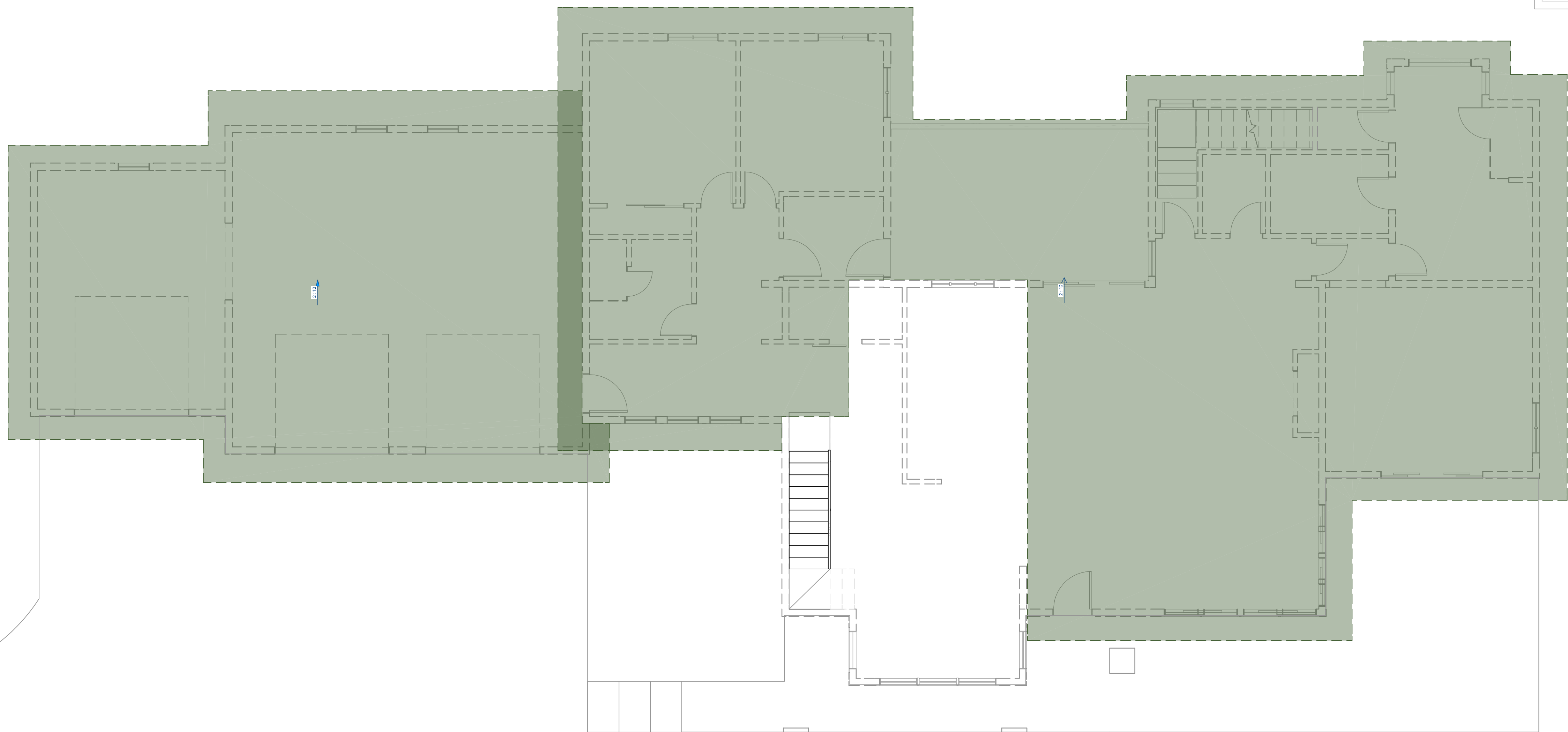

Roof Plan View

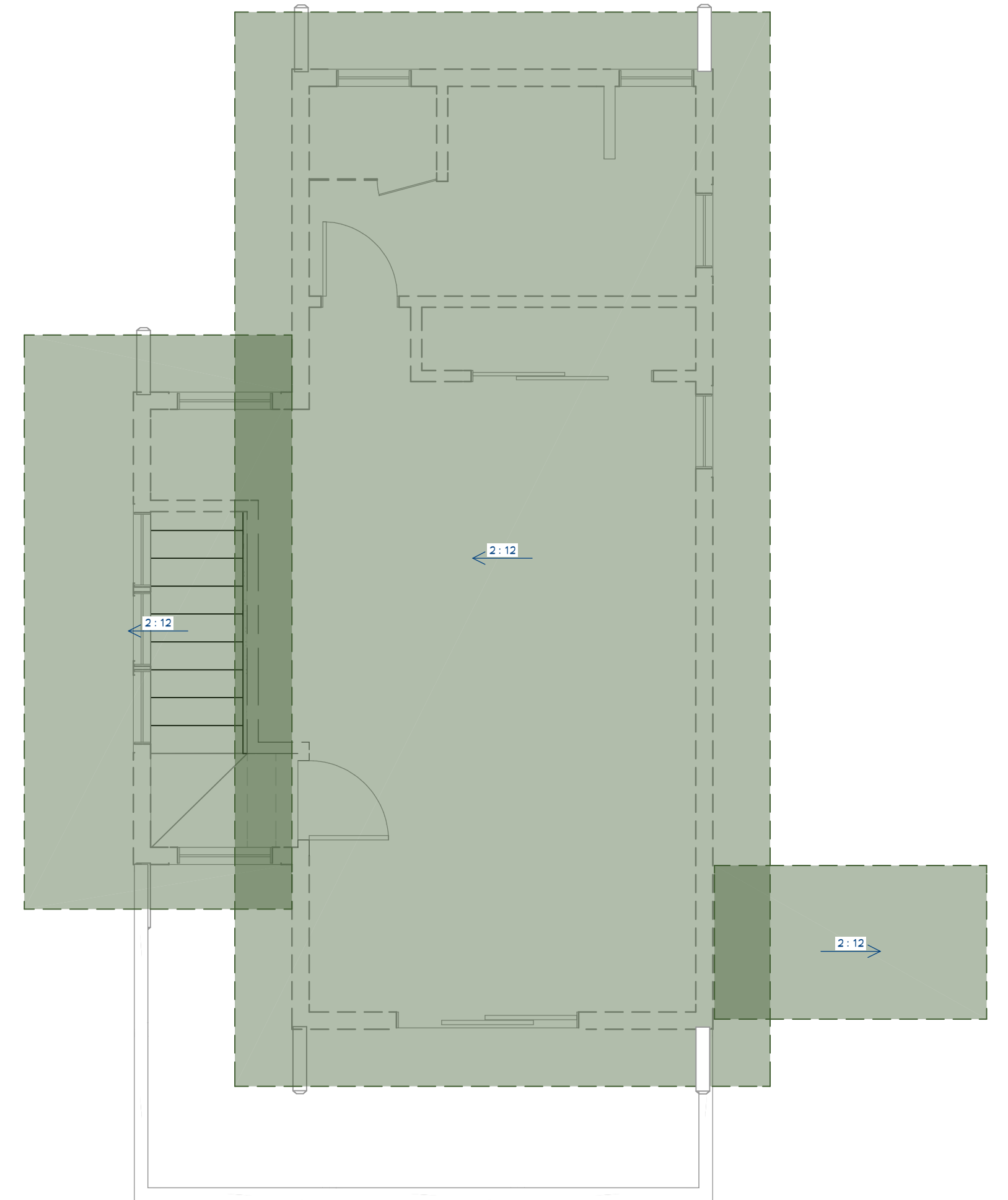

Upper Level
Roof Plan View



Residence for:
Robin and Marius Sutara
542 Great Spirit
Gold Mountain

DRAWINGS PROVIDED BY:
Williams Construction and Design
P.O. Box 161 Clio, Ca. 96106
(530) 308-1703

DATE:

12/27/23

SCALE:

SHEET:

A7

NUMBER	DATE	REVISION BY	DESCRIPTION

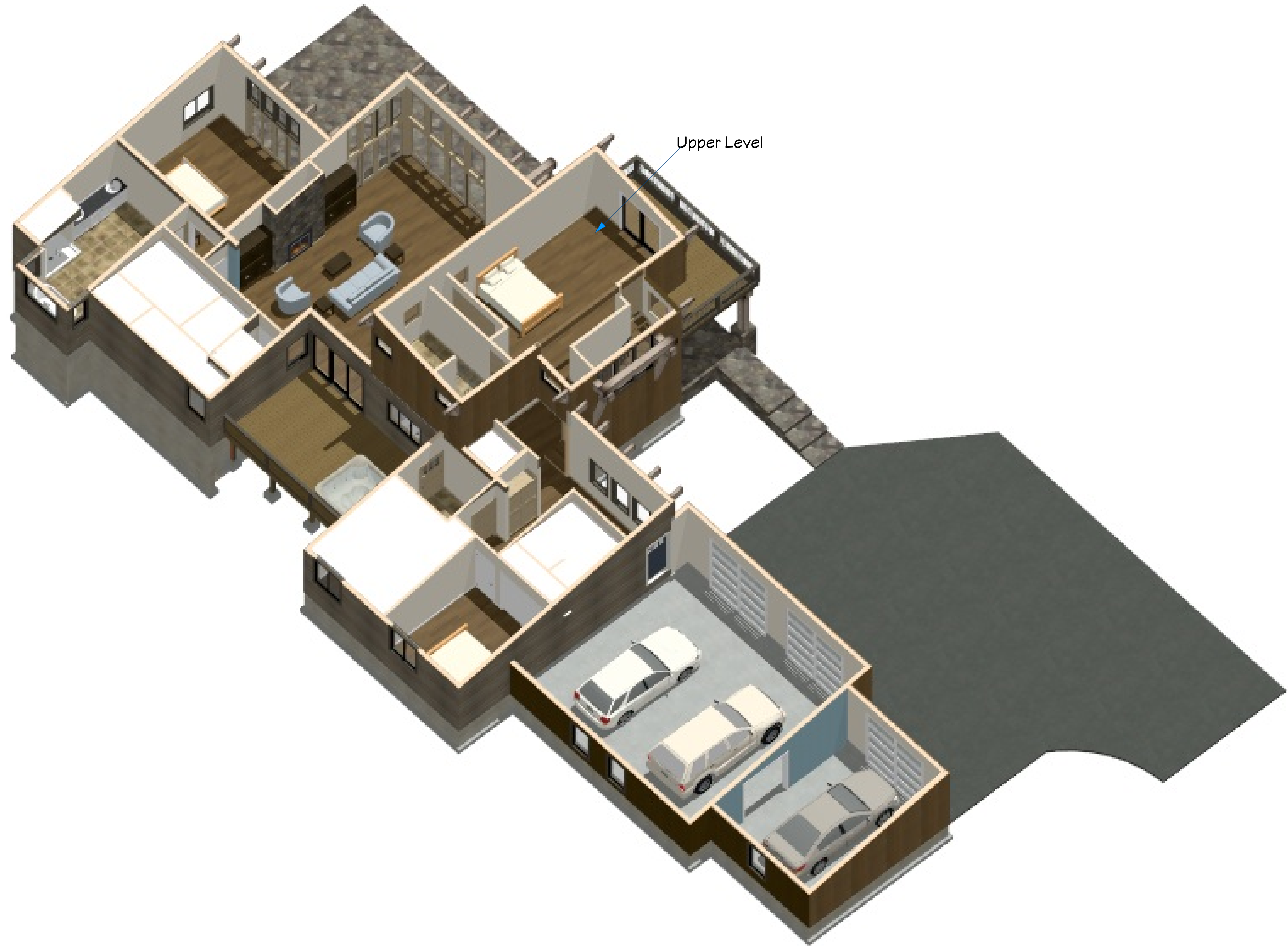

Upper Level

NUMBER	DATE	REVISED BY	DESCRIPTION



Residence for:
Robin and Marius Sutara
 542 Great Spirit
 Gold Mountain

DRAWINGS PROVIDED BY:
 Williams Construction and Design
 P.O. Box 161 Cilo, Ca. 96106
 (530) 308-1703

DATE:

12/27/23

SCALE:

SHEET:

A9

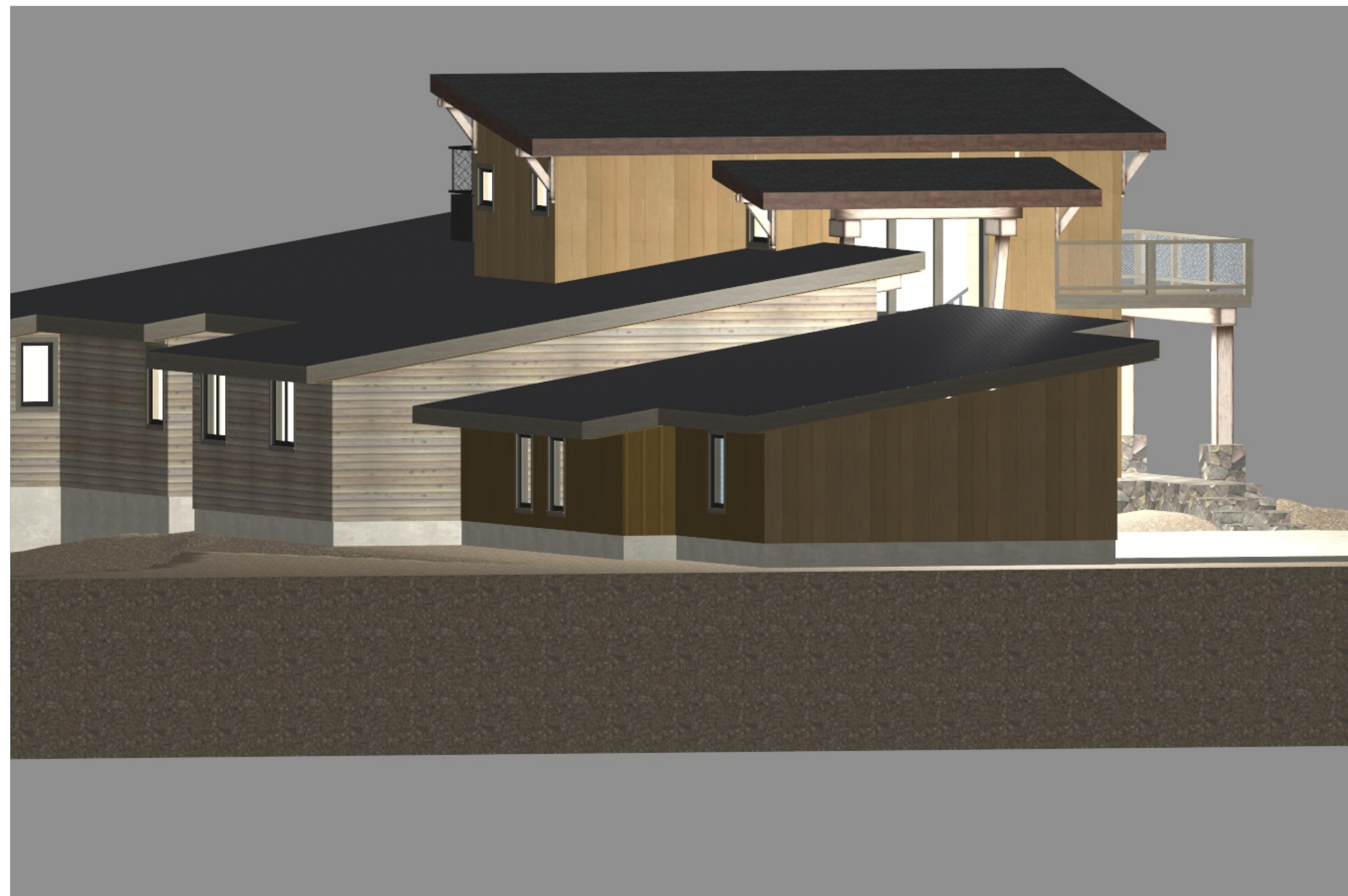

REVISION TABLE			
NUMBER	DATE	REVISOR	DESCRIPTION



Residence for:
Robin and Marius Sutara
 542 Great Spirit
 Gold Mountain

DRAWINGS PROVIDED BY:
 Williams Construction and Design
 P.O. Box 161 Clio, Ca. 96106
 (530) 308-1703

DATE:

12/27/23

SCALE:

SHEET:

A10



a01



a03

NUMBER	DATE	REVISION BY	DESCRIPTION



Residence for:
Robin and Marius Sutara
 542 Great Spirit
 Gold Mountain

DRAWINGS PROVIDED BY:
 Williams Construction and Design
 P.O. Box 161 Clio, Ca. 96106
 (530) 308-1703

DATE:

12/27/23

SCALE:

SHEET:

A11